

# XMC-P2000E-VO

## CHIP-DOWN DESIGN

## NVIDIA® QUADRO® PASCAL™ GP107, 2.3 TFLOPS WITH 4 VIDEO OUTPUTS

### KEY FEATURES

- NVIDIA GP107, 2.3 TFLOPS GPGPU Engine
- Chip-down rugged design, MIL-STD-810
- 4 independent DisplayPort 1.4 outputs
- 4 GB GDDR5 memory with NVIDIA GPUDirect™ DMA
- Operating power default: 25W; configurable hard cap from 15 - 50W

### ADDITIONAL FEATURES

- 4 DisplayPort 1.4 digital video outputs:
  - support for High Dynamic Range (HDR) video
  - 4K at 120Hz or 5K at 60Hz with 10-bit color depth
- Pascal GPGPU parallel processing:
  - 768 CUDA® cores
  - CUDA Toolkit 9, CUDA Compute version 6.1
  - OpenCL™ 1.2, DirectX® 12, OpenGL 4.5, Vulkan 1.0
- Memory width: 128-bit
- Maximum memory bandwidth: 96 GB/s
- NVENC/NVDEC accelerator for HEVC (H.265) and AVC (H.264) hardware encode/decode
- PCIe x8 Gen3

### SPECIFICATIONS

- High level of ruggedization:
  - Rugged air-cooled or conduction-cooled
  - Operating temperature: -40° to +85°C
  - Vibration (sine wave): 10G peak, 5 - 2000Hz
  - Shock: 30G peak for air-cooled, 40G peak for conduction-cooled
- Front I/O and Rear I/O configurations
- Windows and Linux drivers
- VITA 46.9 I/O compliant mapping for 3U and 6U VPX configurations
- Available as XMC 1.0 or XMC 2.0 configurations

### OVERVIEW

The XMC-P2000E-VO board uses NVIDIA's advanced Quadro Pascal 14nm GPU technology. This rugged Pascal-based board includes four DisplayPort 1.4 outputs, which provides support for High Dynamic Range (HDR) video, and resolutions of 4K at 120Hz or 5K at 60Hz with 10-bit color depth.

The rugged XMC-P2000E-VO board includes air-cooled and conduction cooled options. For additional options contact WOLF to discuss MCOTS and custom design services.

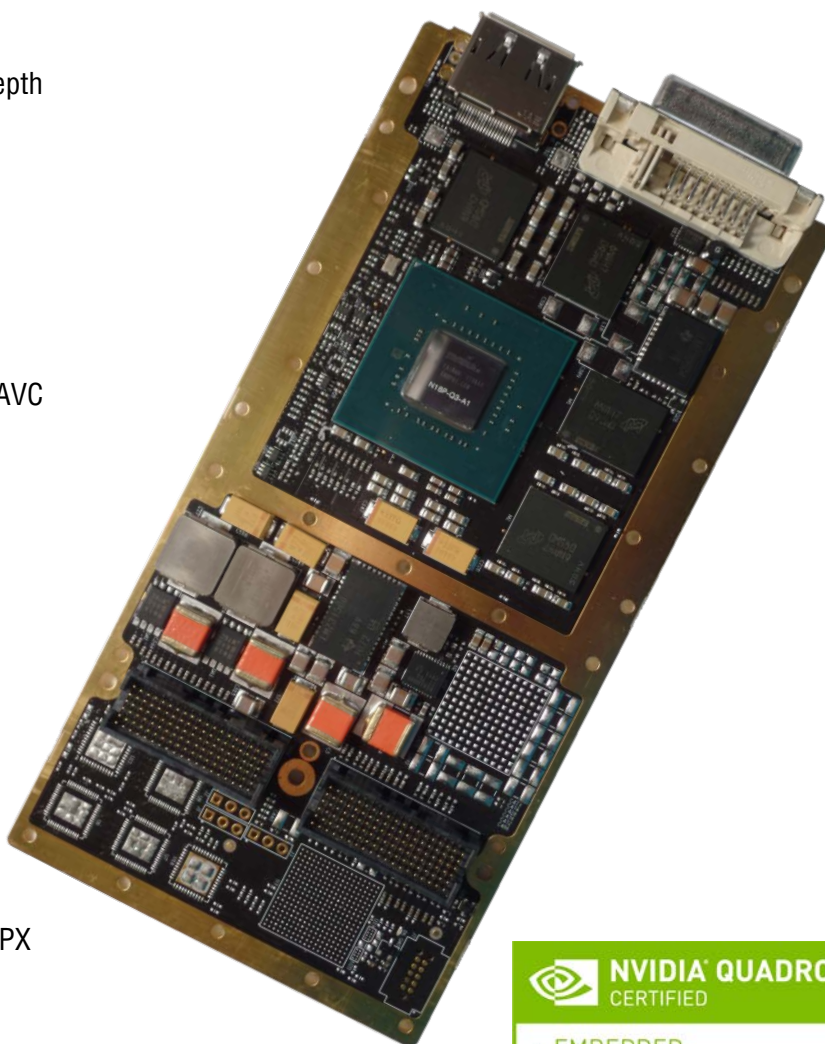

**WOLF- 3176 XMC Module**

## NVIDIA QUADRO PASCAL GP107

Quadro Pascal GP107 is an enormous leap in processing power compared to the previous generation Maxwell GM107. It can provide up to 2.3 TFLOPS of CUDA processing at a very modest operating power, providing a huge improvement to 46 GFLOPS/Watt, making it an excellent choice for aerospace and defense applications. With its impressive processing power the board excels at data processing which benefits from advanced parallel processing, such as video stabilization, image processing, terrain analysis, object tracking or 3D visualization of geospatial data.

Quadro Pascal GPU architecture also provides a more powerful Unified Memory feature. Pascal's larger virtual memory address space enable GPUs to access the entire system memory plus the memory of all GPUs in the system, while the on-demand page migration engine allows the system to migrate pages from anywhere in the system to the GPU's memory for efficient processing. This improved memory handling results in significantly improved algorithm efficiency.

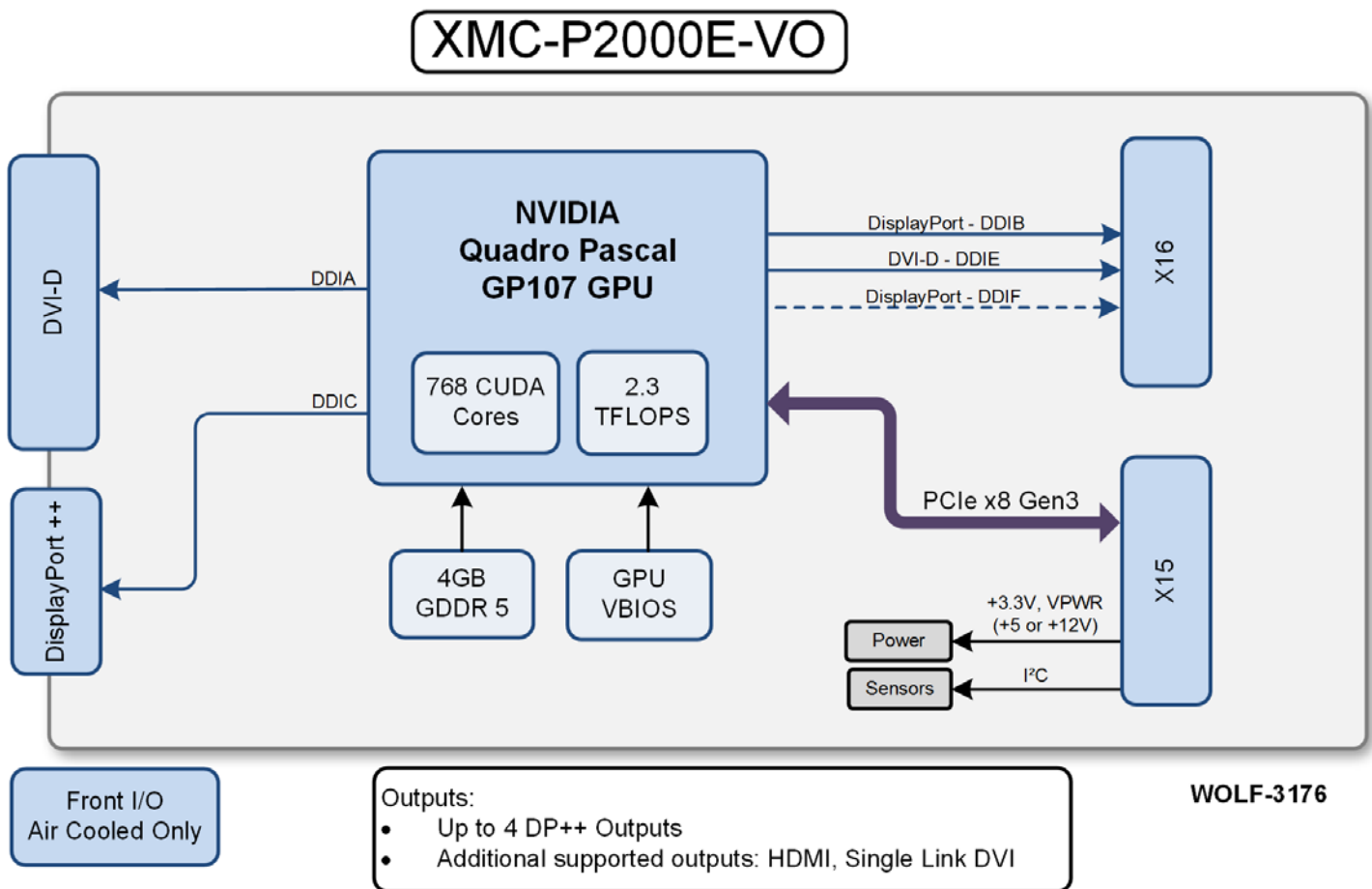

## ORDERING CODES FOR XMC-P2000E-VO

Part Number	Description
317621-F01**XMCv10	Air cooled, XMC 1.0, Front IO: 1xDVI-D, 1xDP 1.4, Rear IO: 3xDP 1.4
317622-F01**XMCv10	Air cooled, XMC 2.0, Front IO: 1xDVI-D, 1xDP 1.4, Rear IO: 3xDP 1.4
317631-F02**XMCv10	Conduction cooled, XMC 1.0, Rear IO: 3xDP 1.4
317632-F02**XMCv10	Conduction cooled, XMC 2.0, Rear IO: 3xDP 1.4

\*\* Contact Sales for code definition. Code can specify: Conformal Coating, Modified Power Cap, Display Termination, other Part Numbers shown for Standard I/O configuration, contact Sales for additional I/O configuration options

## MANUFACTURING AND QUALITY ASSURANCE

WOLF stress tests to MIL-STD-810 (United States Military Standard for Environmental Engineering Considerations and Laboratory Tests) and MIL-HDBK-217 (Reliability Prediction of Electronic Equipment); Alternately will stress test to RTCA DO-160 (Environmental Conditions and Test Procedures for Airborne Equipment) on request.

WOLF products meet the following quality standards:

- ISO 9001:2015 (Quality management systems)
- IPC-A-610 CLASS 3 (Acceptability of Electronic Assemblies)
- IPC 6012 CLASS 3 (Qualification and Performance Specification for Rigid Printed Boards, Class 3 for High Reliability Electronic Products)
- IPC J-STD-001 Certified (Requirements for Soldered Electrical and Electronic Assemblies)

Boards are manufactured to meet the following standards:

- SAE AS9100D (Quality Management System - Requirements for Aviation, Space and Defense Organizations)
- SAE AS5553 (Counterfeit Electronic Parts; Avoidance, Detection, Mitigation, and Disposition)



WOLF- 3176 XMC Module