

VPX3U-XAVIER-SBC

SBC includes Xavier with Volta GPU & Carmel CPU, WOLF FGX

KEY FEATURES

- NVIDIA Volta GPU with 512 CUDA cores & 64 Tensor cores, 1.4 TFLOPS, 22.6 DL TOPS Int8
- NVIDIA Carmel ARM64 CPU with 8 cores, 2.26GHz
- 32 GB or 16 GB LPDDR4 256-bit memory with up to 137 GB/s
- WOLF FGX provides support for additional video formats such as SDI and CVBS
- Module power: 30-50W

ADDITIONAL FEATURES

- 3x DisplayPort 1.2a up to 4K-UHD, or HDMI / DVI
- 2x SDI outputs, 2x CVBS outputs
- 2x Deep Learning Accelerator (DLA) engines for inference operations, 11.4 TOPS Int8
- 2x Vision Accelerator engines for 7-way VLIW Vision Processor, 1.7 TOPS Int8
- Dedicated programmable audio processor
- 2x HEVC (H.265) and AVC (H.264) Volta NVENC and NVDEC with up to 4K-UHD encode resolution
- 2x 1000BASE-T Ethernet
- CUDA® 10, OpenGL® 4.6, OpenGL ES 3.2, Vulkan™ 1.0
- Flash Storage: 32 GB eMMC 5.1 with support for ECC
- Optional M.2 NVME SSD, 256GB to 1TB
- Optional SATA connection through P2
- USB ports with support for USB 3.1 Gen 1 (5 Gb/s) and USB 2.0 (up to 480 Mb/s)
- PCI Express Gen3 x8, x4
- Daisy Chain and NTB Options Available
- Standalone operation or connect to Windows, Linux or ARM root complex

SPECIFICATIONS

- High level of ruggedization:
 - Rugged Air or Conduction cooled
 - Operating temperature: -40° to +85°C
 - Vibration (sine wave): 10G peak, 5 - 2000Hz
 - Shock: 30G peak for air-cooled, 40G peak for conduction-cooled
- Dimensions: 160mm x 100mm x 25.4mm
- Weight: To be Announced
- +12V or +5V Only Power Source Options
- ANSI/VITA 48, 65 (VPX REDI, OpenVPX)

OVERVIEW

The VPX3U-XAVIER-SBC module includes both an NVIDIA Jetson AGX Xavier and a WOLF FGX in a rugged 3U VPX module. The Jetson AGX Xavier SoC includes an advanced Volta GPU, Carmel ARM64 CPU, and additional accelerator circuits for deep learning inference, machine vision, audio processing and encoding/decoding. The Xavier SoC also achieves a huge upgrade in power efficiency thanks to a 12nm fabrication process. The WOLF FGX provides support for video formats which are not native to the GPU.

The Volta GPU with its Tensor cores provides this module with the underlying architecture required for an efficient inference engine. The module can achieve up to 32 TeraOPS (TOPS) of deep learning inference computing using the GPU and Deep Learning Accelerator (DLA) engines. Intended to work in conjunction with TensorRT, CUDA and CuDNN, the Tensor Cores supports Int8 and experimental Int4 / 1-bit matrix operations.

Unlocking the best performance requires the best cooling capability. WOLF's advanced cooling technology is designed to move heat using a low weight, high efficiency pipeline from the SoC die to the wedgelocks.



VPX3U-XAVIER-SBC

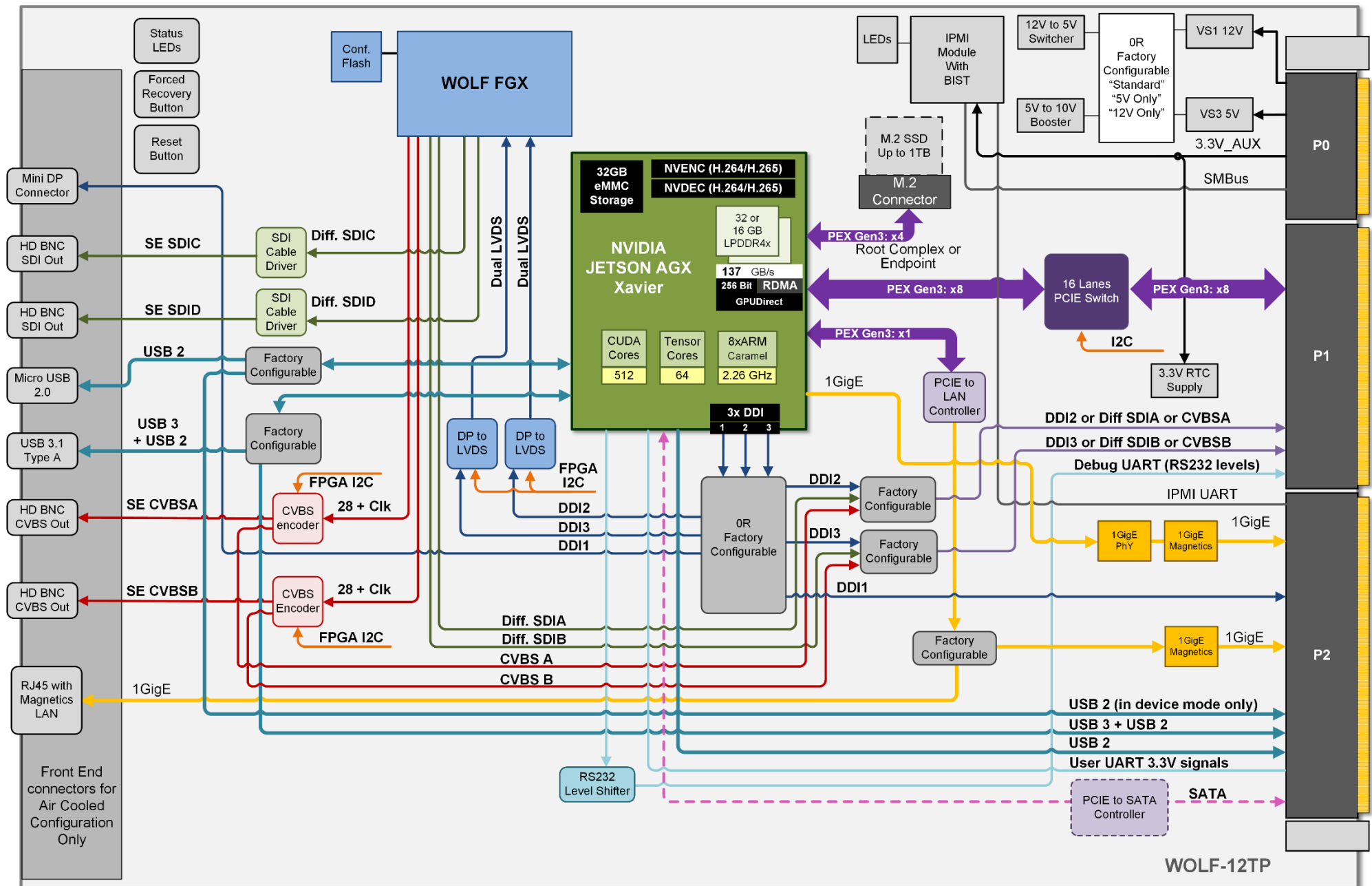

WOLF-12TP

NVIDIA AGX XAVIER

The AGX XAVIER autonomous machine accelerator technology is designed to allow computer vision and deep learning to be deployed to the edge. The extremely power efficient 12nm AGX Xavier SoC can provide up to 32 TeraOPS (TOPS) for Deep Learning inference computing at just 30W.

The module can also benefit from NVIDIA's rich set of AI tools and workflows as well as the NVIDIA JetPack SDK.

DESIGNED FOR SYSTEM INTEGRATION

The VPX architecture is diverse, spanning custom backplanes, an ambiguous system specification and differing input and output methodologies. That is precisely why WOLF modules come with factory configuration options to solve virtually all system integration challenges.

The WOLF-12TP has been designed to include a WOLF FGX to support additional video formats that are not native to the Xavier GPU, including SDI and analog formats. The FGX also allows WOLF to react quickly to customer requirements for additional video formats as MCOTS products.

This module has been designed to support VPX REDI (VITA 48) and OpenVPX (VITA 65).

SYSTEM COMPATIBILITY

There are several groups spearheading initiatives to develop standards to ensure compatibility between systems and vendors, with the aim of reducing the time and cost required to deploy new technology. The 12TP includes a new 3U VPX Interface Control Document (ICD) that includes factory configurable options which can be used to maintain compliance with many of these initiatives.

This module has been designed to be SOSA aligned and uses the SOSA 3U VPX SBC slot profile. For PCIe X8 upstream and X4 upstream / X4 downstream this module is also compatible with various OpenVPX slot profiles.

Standard slot profiles available for this module:

- SLT3-PAY-1F1F2U1TU1T1U1T-14.2.16 (SOSA aligned 3U I/O Intensive SBC Slot Profile)
- MOD3-PAY-1F1F2U1TU1T1U1T-16.2.15-1 (VITA 65 3U Payload Module Profile)
- MOD3-PAY-1F1F2U1TU1T1U1T-16.2.15-2 (VITA 65 3U Payload Module Profile)

Contact WOLF to discuss the presence of a specific interface, or to discuss a different Module Profile.

HARDWARE ACCELERATED VIDEO ENCODE / DECODE

The Xavier includes two NVENC (encoder) and two NVDEC (decoder) engines. The dedicated encoding engine provides an extremely power efficient method to encode up to 4K resolution video to H.264 or H.265. The NVENC supports up to 15 Mbps for 1080p and up to 60 Mbps for 2160p, CBR and VBR rate control, programmable intra-refresh for error resiliency, and a motion estimation (ME) only mode. The NVIDIA Video Codec SDK provides a complete set of APIs, samples and documentation for hardware accelerated video encode and decode on Windows and Linux.

ORDERING CODES

The following table defines series of common order codes for the VPX3U-XAVIER-SBC module. The asterisks denote characters of the part number that are defined based on common configuration options. Some common configuration options for this module are:

- PCI Express Bus P1 Configuration
- Conformal Coating Type
- +12V / +5V Main Power
- Default Power Threshold
- SDI and CVBS Output Modes
- Display Interfaces
- COTS, MCOTS or Locked
- Optional SSD

Ordering Number	Description
3U VPX AGX Xavier Single Slot Configurations	
12TP23-F0**VPX3v10	3U VPX, Air Cooled, 1", NVIDIA Xavier, WOLF FGX
12TP33-F0**VPX3v10	3U VPX, Conduction Cooled, 1", NVIDIA Xavier, WOLF FGX

Contact Sales for the latest Ordering Numbers and available options

MANUFACTURING AND QUALITY ASSURANCE

WOLF designs modules to pass the following environmental standards:

- MIL-STD-810 (United States Military Standard for Environmental Engineering Considerations and Laboratory Tests)
- MIL-HDBK-217 (Reliability Prediction of Electronic Equipment)
- RTCA DO-160 (Environmental Conditions and Test Procedures for Airborne Equipment) on request

WOLF complies with the following management systems:

- AS9100D: Quality Management System - Requirements for Aviation, Space and Defense Organizations (certified)
- ISO 9001:2015: Quality management systems (certified)
- AS5553: Counterfeit Electronic Parts; Avoidance, Detection, Mitigation, and Disposition (compliant)
- NIST SP 800-171: Protecting Controlled Unclassified Information in Nonfederal Systems (compliant)

Boards are manufactured to meet the following standards:

- IPC-A-610 CLASS 3 (Acceptability of Electronic Assemblies)
- IPC 6012 CLASS 3 (Qualification and Performance Specification for Rigid Printed Boards, Class 3 for High Reliability Electronic Products)
- IPC J-STD-001 (Requirements for Soldered Electrical and Electronic Assemblies)

Caveat: integrated third party modules may not meet the same standards as WOLF manufactured modules.

