

Unsticht1
Maßstab 1:3
A

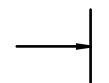

434.6

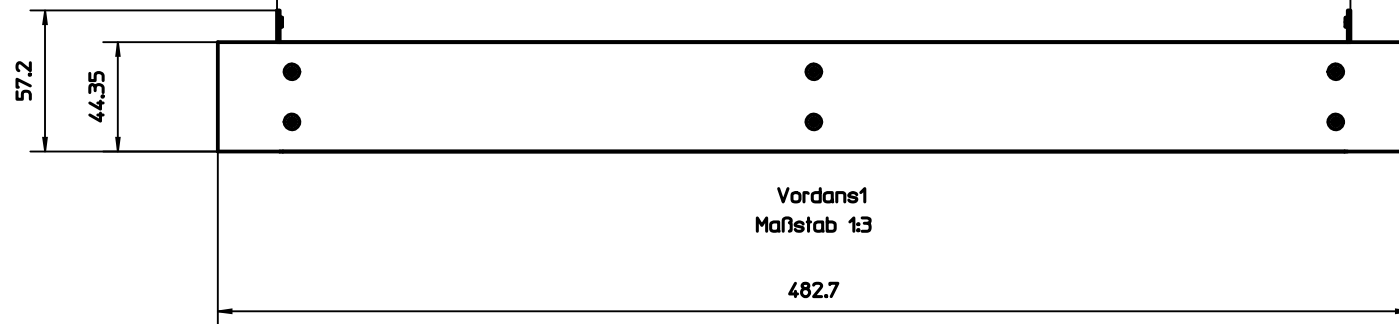

Vordans1
Maßstab 1:3

482.7



A

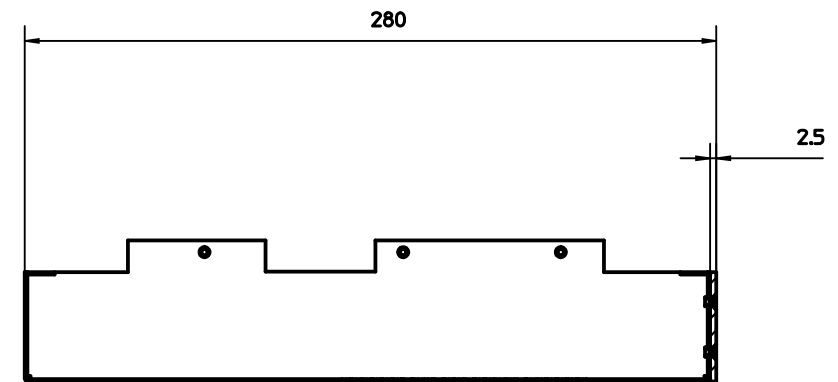

Schnitt A-A
Maßstab 1:3

Zeichnungsart				Maßstab	
Montage				1:3	
				Datum	Name
				Bearb. 04.06.10	Be
				Gepr. 24.05.11	Be
				Freig. 24.05.11	HM
				 HARTMANN ELEKTRONIK	
Zust.	Änderung	Datum	Name		

Vormaterial:	mm dick
Vorm.Oberfl.:	
Werkstoff :	
Oberfläche :	
b120a084l01k01	
Lüftereinheit 1HE/84TE	
b120a084l01k01	
Fa. Hartmann	1 Bl.

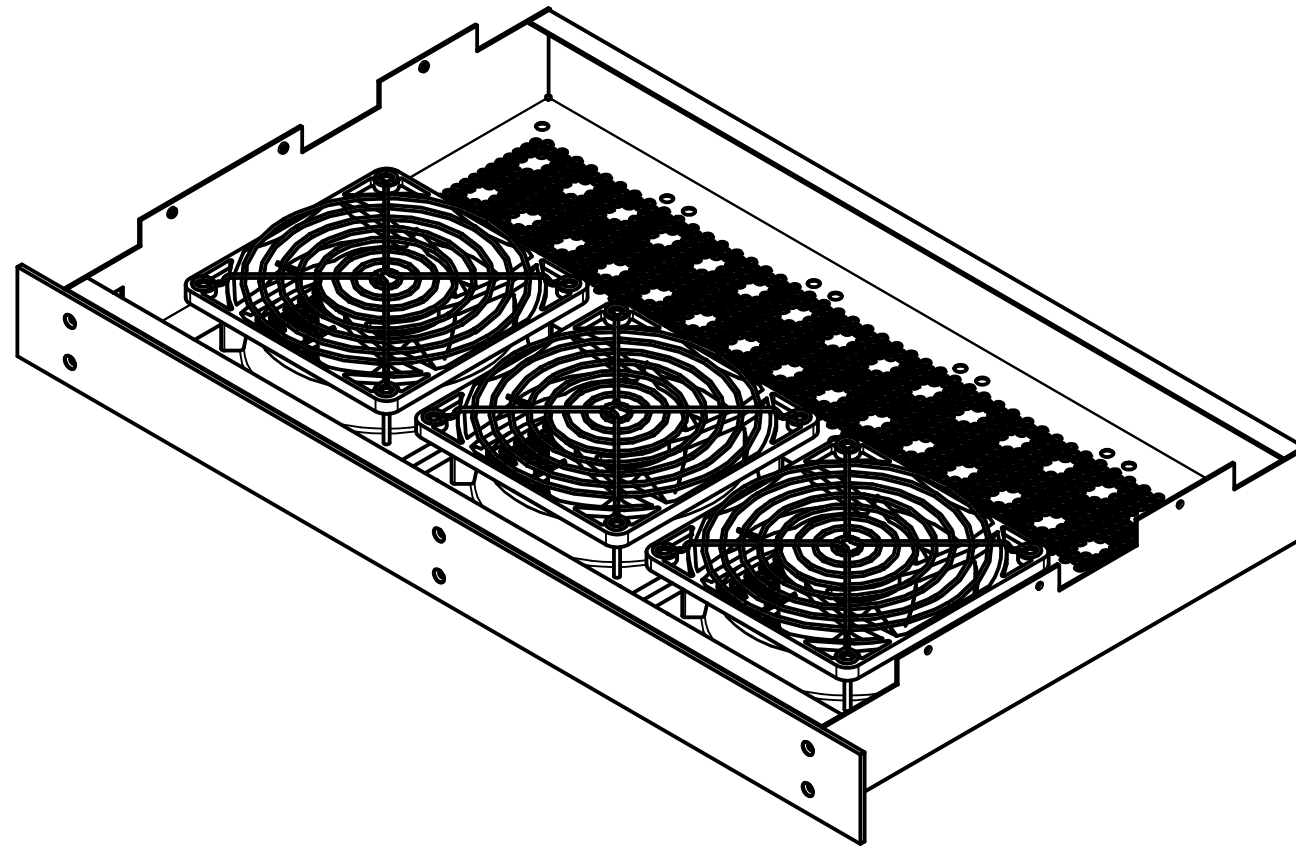

IS02

Zeichnungsart				Maßstab	
Montage				1:3	
				Datum	Name
				Bearb. 04.06.10	Be
				Gepr. 24.05.11	Be
				Freig. 24.05.11	HM
				 HARTMANN ELEKTRONIK	
Zust.	Änderung	Datum	Name		

Vormaterial:	mm dick
Vorm.Oberfl.:	
Werkstoff :	
Oberfläche :	
b120a084l01k01	
Lüftereinheit 1HE/84TE	
b120a084l01k01	
Fa. Hartmann	2 Bl.